

Visilume Standard Sightglass

(also available complete with Wiper Assembly)

Application:

Weld-on low pressure sightglass fittings for observing the internals of tanks, pressure vessels, silos, gear-trains, separators and pipelines etc.

General:

Visilume low pressure sightglasses are similar to the DIN28-120 series and are suitable for welding into or onto vessel walls. The reduced dimensions provide a cost effective alternative for low pressure applications. Available in sizes from 50mm to 600mm viewing diameters.

Operating Conditions:

Rated for pressures up to 5 bar depending on size. Temperature rating up to 900°C depending on seal and glass selection.

Standard of Construction:

Construction based on guidance of the German Standard DIN28120 and relevant parts of BS PD5500 and ASME VIII, div 1 standards. Meets all requirements of the Pressure Equipment Directive 2014/68/EU.

Combinations:

Sightglass units can be combined with a range of light fittings for use in hazardous or safe areas. Also available with wiper unit.

Certificate and Pressure Testing:

Material test certificates to EN10204-3.1 are issued with all flanges. Pressure testing can be provided at extra cost.

Material of components:

(referred to in adjoining exploded view)

Item	Part	Material options
1	Base Flange: (welding flange)	Stainless steel 316L or 304L, carbon steel.
2	Gaskets	NAF, PTFE, Viton, food quality Silicone rubber or micaceous material for high temperature applications.
3	Sight glass disc	Toughened or Annealed Soda Lime (up to 150°C) to DIN8902 or BS3463 / Toughened Borosilicate (up to 280°C) to DIN7080 or BS3463, Quartz (up to 900°C).
4	Cover flange	Stainless steel 316L or 304L carbon steel.
5	Securing bolts	Stainless steel A2 grade or carbon steel.

Other materials are available upon request.

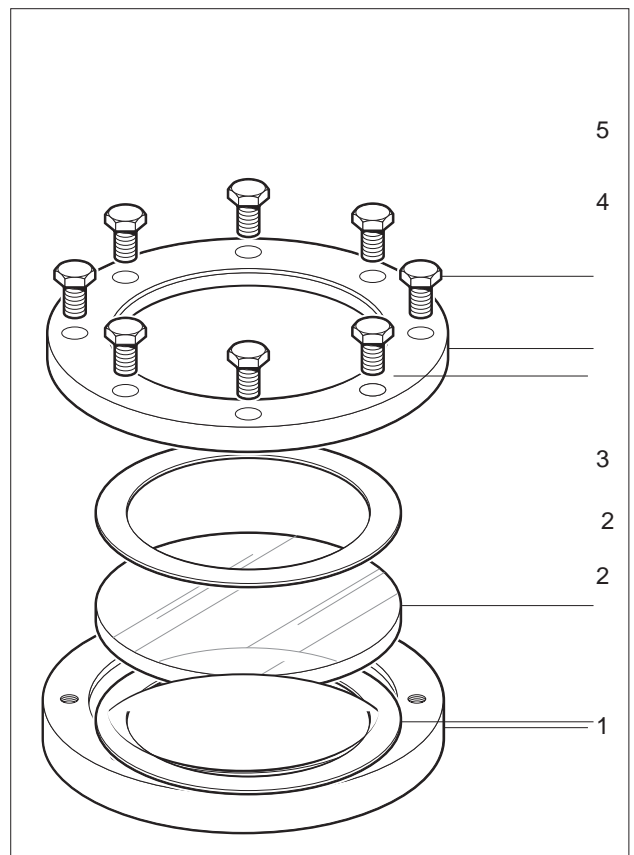

Exploded view of circular sightglass unit.

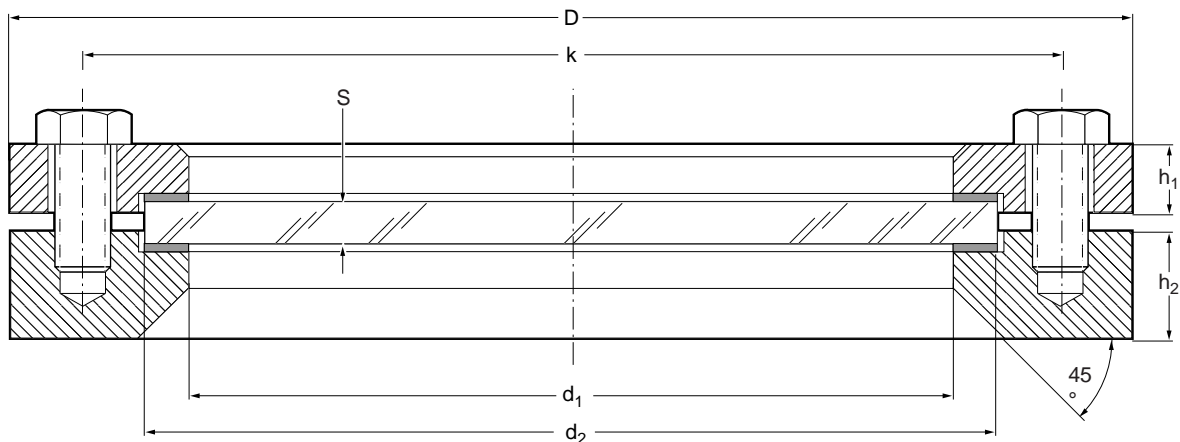

Size		1	2	3	4	5	6	7	8	9	10
Pressure rating	bar	5	5	5	5	5	5	4	4	3	3
Viewing diameter	d1	50	80	100	125	150	175	200	225	250	300
Sight glass disc	d2	60	89	114	150	175	200	225	250	275	325
	S (TSL)	10	12	12	15	15	15	15	n/a	n/a	n/a
	S (TBS)	10	12	12	20	20	25	25	20	20	30
Flanges	D	100	150	177	202	228	254	280	304	345	405
	h1	16	16	16	16	16	16	16	19	19	19
	h2	25	25	25	25	25	25	25	30	30	30
Bolts	K	78	127	152	178	204	229	256	280	304	366
	No.	4	4	4	8	8	8	8	8	8	8
	Size	M12	M12	M12	M12	M12	M12	M12	M12	M12	M12
	Length	30	30	30	35	35/45	35/45	35/45	40/45	40/45	45/55

Visilume Standard Sightglass Fitting with Wiper - Borosilicate glass

Size		1	2	3	4	5	6	7	8	9	10
Pressure rating	bar	N/A	5	5	5	5	4	2	4	1.6	1
Viewing Diameter	d1	50	80	100	125	150	175	200	225	250	300
Sight glass disc	d2	N/A	89	113	150	175	200	225	250	275	325
	S	N/A	12	15	19	19	19	15	25	20	15

Visilume Standard Sightglass Fitting with Wiper - Soda-Lime glass

Soda-Lime: [Annealed](#) / [Toughened](#)

Size		1	2	3	4	5	6	7	8	9	10
Pressure rating	bar	N/A	5	3	5	4	4	2	2	0.8	0.5
Viewing Diameter	d1	50	80	100	125	150	175	200	225	250	300
Sight glass disc	d2	N/A	89	114	150	175	200	225	250	275	325
	S	N/A	12	12	15	15	15	15	15	15	15

Ordering Information

Please specify the selected items as follows:

Fittings: Viewing diameter

Material: Base (welding) flange, bolts, cover flange, glass disc, gaskets.

All dimensions in mm unless otherwise stated.
Subject to change without notice.

Installation: After welding the base flange (1) into the vessel wall, gaskets (2), sight glass disc (3) and cover flange are carefully placed in the order shown. Then the bolts (5) are progressively tightened, always working on diametrically opposed pairs of bolts each time.