

Type 80.NA

METACLAMP® for Flush Mounted NA-Connect™ Fitting

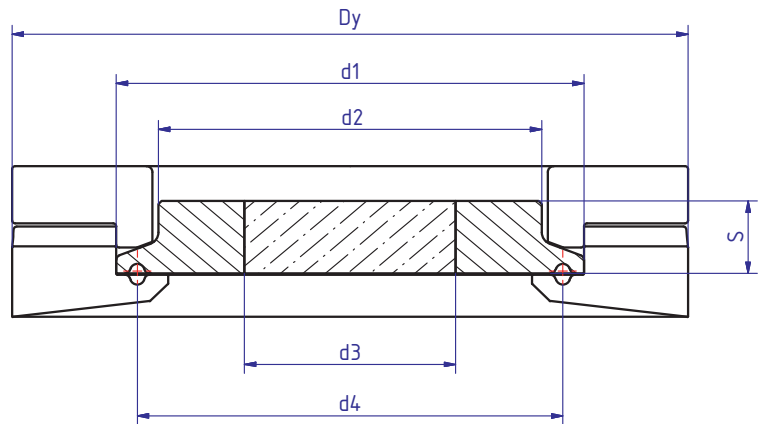
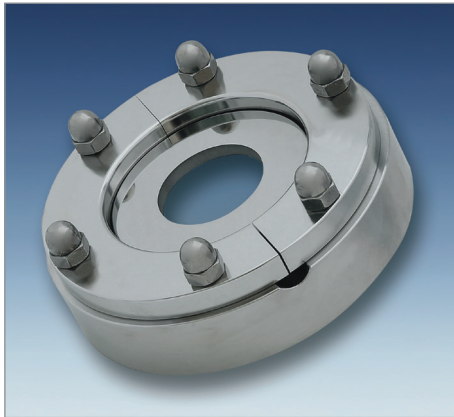

Overview

- Type 80.NA Metacamp is designed to fit the flush-mounted NA-Connect system to offer clear process visibility and unmatched safety with easy cleaning and sterilization.
- The NA-Connect Sight glass eliminates the dead leg created by a standard sanitary ferrule connection avoiding air pockets and trapped undissolved material.

Advantages

- Suitable for aseptic pharmaceutical and food applications (3-A Standard)
- Easy validation of connection for sterilization and cleaning
- Extremely compact construction
- Simple installation and maintenance
- Glass resistant to catastrophic failure
- Long working time

Ring

materials	Temperature (TS)
1.4462	-30°C bis +280°C
2.4602	-60°C bis +300°C
2.4610	-60°C bis +300°C

Technical data Manufactured and tested to:

- Directive for pressure equipment 2014/68/EU, Module H (DIN/EN/ISO 9001)
- AD2000 Standards W0/TRD 100
- Sight glass fused to metal conforming to DIN 7079
- Materials to VdTÜV specifications and the DIN/EN designated standards
- Glass: Borosilicate to DIN 7080 / DIN 7079

Material certificates

- Certificate of Conformity to EN 10204-3.1 or 3.2

Operating conditions

- Pressure: Up to 7 bar
- For connector NA-Connect dimensions and technical data please request data sheet NAC00-S

Nominal size			PN	d1	d2	d3	d4	S	Dy
DIN	ISO	ASME BPE							
-	8/10	1/2" / 3/4"	25	25,0	18	10	20,4	10	55
10/15/20	-	-	25	34,0	18	10	27,5	8	70
25/32/40	15/20/25	1 1/2" / 1"	16	50,5	38	25	43,5	10	85
50	32/40	2"	16	64,0	52	30	56,5	10	100
-	50	2 1/2"	16	77,5	63,5	35	70,5	10	112
65	65	3"	10	91,0	76	40	83,5	10	131
80	80	3 1/2"	10	106,0	90	50	97,0	10	140
100	-	4"	10	119,0	101	55	110	12	170
-	100	4 1/2"	10	130,0	114	60	122	16	170