

Holder for bursting discs

Type BHS for pipe connections

We offer matching bursting disc holders to ensure safe installation and optimal functionality of our bursting discs.

Due to its excellent material properties this bursting disc holder is particularly suitable for applications in the pharmaceutical and food industry.

Benefits

- The system can be flexibly combined with various pipe screw couplings and bursting discs
- Very good corrosion and acid resistance as well as average roughness values
- Certified welds according to the Pressure Equipment Directive 97/23/EC
- Cost advantage: the BHS can be reused after the bursting disc has opened
- Simple installation
- With integrated burst detection available

Description

Berstscheiben Schlesinger has developed the BHS bursting disc holder made of stainless steel to facilitate optimal installation of bursting discs in screw couplings for pipes.

Highlight: The BHS can easily be adapted to a wide variety of pipe types - with clamp, ISO-K, ISO-KF or hygienic couplings.

It is also possible to use different bursting disc types in the BHS: simple and domed composite bursting discs as well as rupture and reverse buckling bursting discs.

The BHS remains undamaged when the bursting disc bursts and can thereafter be reused.

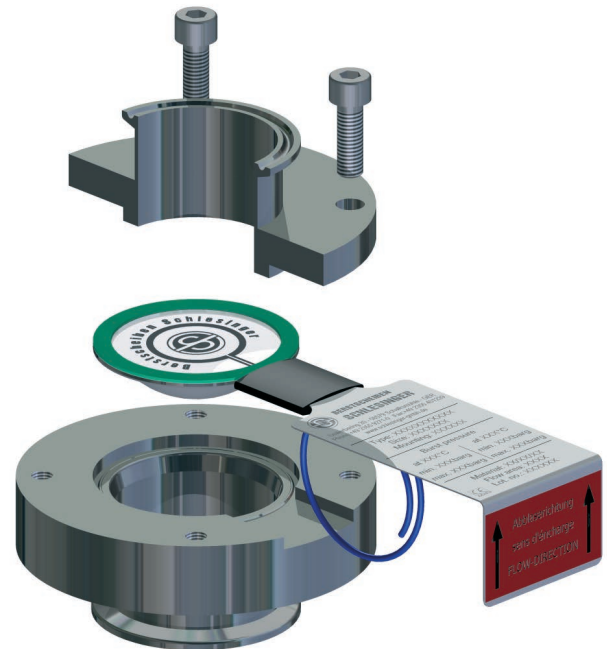

Reverse buckling bursting disc with membrane signal transmitter in bursting disc holder type BHS

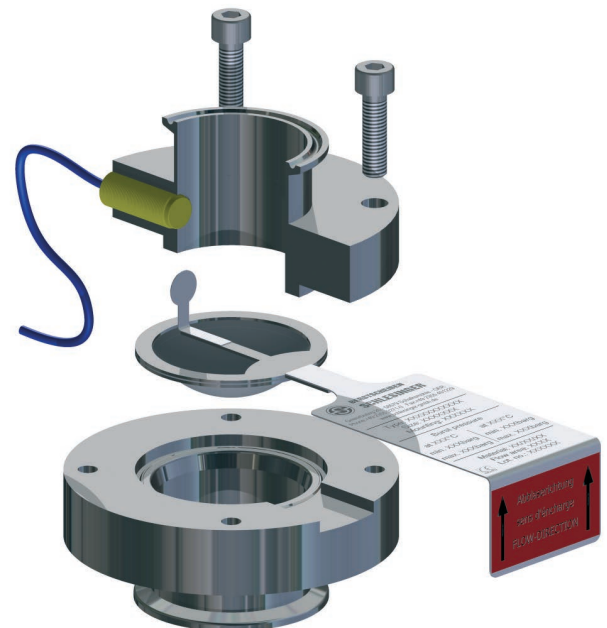

Reverse buckling bursting disc and transmitter with inductive proximity switch in bursting disc holder type BHS

Installation

The BHS bursting disc holder is adapted to a pipe. The bursting disc is centred in the holder. A defined fastening torque can be achieved across several screw connections. By using a sealing lip, we can realize the smallest leakage rates.

Additional equipment

The BHS can furthermore be equipped with burst monitoring. This is either based on a signal transmitter with an inductive proximity switch that is directly installed into the BHS or a membrane signal transmitter that is part of the bursting disc to be installed. Both systems provide a signal to the process control system connected when the bursting disc opens.

Technical data

General remarks	
Can be combined with the following bursting discs types:	simple and domed composite bursting discs, rupture discs, reverse buckling bursting discs
Media	gas, steam, liquid
Temperature range	-40°C to +550°C
Can be combined with the following screw couplings:	Clamp (DIN 32676) Clamp (ISO 2852) Clamp (ASME BPE) ISO-K (DIN 25404) ISO-KF (DIN 28403) Hygienic pipe (DIN 11851)

*Combinations with other couplings on request.

Mechanical specifications	
Material	Stainless steel
Average roughness value	< 0,8 µm

Dimensions	
Standard	DN 25 to DN 100

Certifications	
CE marking according to Directive 2014/68 EU	
QM-system according to ISO 9001:2015	