

Type 275

METAGLAS® Glass Lined METAGLAS® Sight glass

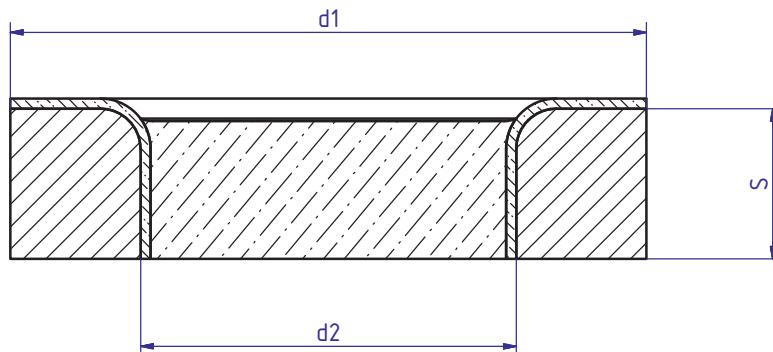
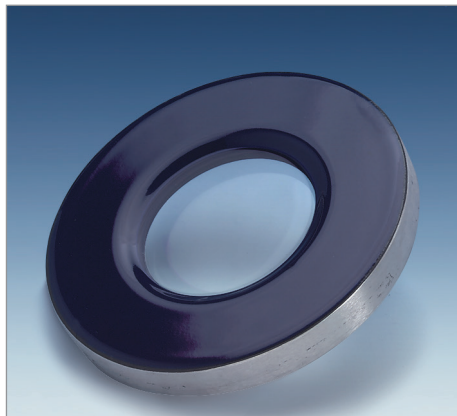

Applications

- Glass lined vessels
- Sight glass fittings to DIN 28121
- Through flow sight Glasses to DIN 3236, DIN 3237

Advantages

- Glass lined METAGLAS® sight glasses combine the security of failsafe fused glass with the excellent characteristics of a Glass surface.
- Advantages of glass lining:
 - The product will only come into contact with polished glass
 - Highly resistant to corrosive processes
 - Inert surface so cannot adversely affect product purity
 - No catalyst effect and no infection
 - Resists build up of sticky products which gives: Better heat transfer & higher productivity

Technical data Manufactured and tested to:

- Directive for pressure equipment 2014/68/EU, Modul H/H1 (DIN/EN/ISO 9001)
- AD2000 Standards W0/TRD 100
- Sight glass fused to metal similar to DIN 7079
- Materials to VdTÜV-specifications and the DIN/EN designated standard

Safety

- Leaktight with very high pressure resistance
- High safety factor
- Shatterproof with reliability against total failure. The possibility of unexpected rupture is excluded
- High resistance to bending and overtightening offers simple, fast installation with no risk of breakage
- Remains leak tight even when Glass is damaged

Ring material

- P 265 GH (1.0425) EN 10028-2
- Sight glass: B270 / 0092
- Enamel DD 3009 blue or white

Approvals

- TÜV-Approval in accordance with governing standards (for pressure vessels)

Operating Temperature:

- -60°C to 250°C

Nominal size		Pressure rating (PS) -1/10 bar			Pressure rating (PS) -1/16 bar		
DN	Zoll	d1	d2	S	d1	d2	S
50	-	102	50	20	102	50	20
-	-	127	75	23	127	75	28
80	3"	137	80	25	137	80	30
100	-	158	95	30	158	95	33
150	-	214	130	35	214	130	40
200	-	269	150	40	269	150	45