

## Lumiglas Sight Glass Disc, Circular DIN 7080

Dimension D x s (mm)	Viewing Diameter d <sub>1</sub> (mm)	Nominal Pressure (bar)
DIN-Sizes		
63 x 10	48	16
80 x 12	65	16
94 x 11 <sup>1)</sup>	80 <sup>1)</sup>	6
100 x 15	80	16
113 x 15 <sup>1)</sup>	100 <sup>1)</sup>	6
125 x 15	100	10
125 x 20	100	16
141 x 15 <sup>1)</sup>	125 <sup>1)</sup>	6
150 x 20	125	10
150 x 25	125	16
166 x 15 <sup>1)</sup>	150 <sup>1)</sup>	6
175 x 20	150	10
175 x 25	150	16
200 x 20	175	8
200 x 25	175	10
200 x 30	175	16
250 x 25	225	8
250 x 30	225	10
<b>Additional dimensions available shown on Page 2</b>		

<sup>1)</sup> As supplement to DIN standard for screwed sight glass fittings similar DIN 11851 – no DIN-dimension!

- For pressure duties at temperatures up to 280°C. No lower temperature limit
- Toughened borosilicate glass
- Ground and polished
- Optional extras possible, e. g. coating!

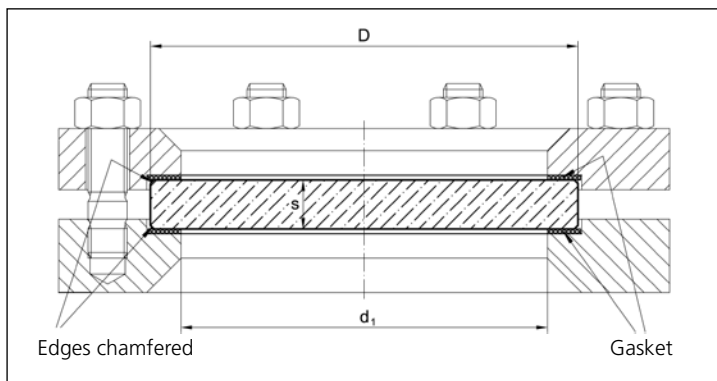

All dimensions in mm unless stated otherwise. Subject to change without prior notice. 09.15



### • Safety precautions when using sight glass discs:

1. Whenever a sight glass assembly has been taken apart it is urgently recommended in accordance with DIN 7080 that the glass disc and gaskets are replaced by new ones. That is particularly important in the case of pressure vessels and/or aggressive media.

### The following extract from DIN 7080 text is verbatim:

'Sight glass discs may only be installed by personnel who have been informed fully about the following requirements:

- care in handling sight glass discs
  - cleaning of recesses, sight glass discs, gaskets and other parts i. e. removal of foreign bodies (e. g. swarf), prior to installation/reassembly
  - even tightening of retaining bolts
- Sight glass discs that have been removed after operating use must not be re-used.'

### 2. Planned maintenance:

Sight glass discs should be included in routine maintenance and periodically checked visually or using ultrasound wall thickness measuring means. In the event of damage, a glass disc must be promptly exchanged, with the plant first having been brought to a standstill.

The service life of a sight glass – relative to the particular vessel in which it is mounted – should be established by regular and careful visual check of its condition.

**Caution:** Completely demineralised water may dissolve glass – especially intensive periodical inspection required!

### 3. Breakage of a sight glass:

In spite of careful installation and recommended use, sight glass discs can, on rare occasions, suffer breakage through external influences. In order to prevent the entry of glass particles into products of a critical nature, e. g. foodstuffs, appropriate safety precautions should be taken by the plant manufacturer or user.

Additional sizes available:

Dimensions d <sub>1</sub> x s (mm)	Inspection aperture d <sub>2</sub> (mm)	Permissible pressure in bar	Dimensions d <sub>1</sub> x s (inch)	Inspection aperture d <sub>2</sub> (inch)	Permissible pressure in psi
45 x 10	32	40	1.772 x 0.394	1.260	580
45 x 12	32	50	1.772 x 0.472	1.260	725
50 x 10	35	25	1.969 x 0.394	1.378	363
50 x 12	35	40	1.969 x 0.472	1.378	580
60 x 10	45	16	2.362 x 0.394	1.772	232
60 x 12	45	25	2.362 x 0.472	1.772	363
60 x 15	45	40	2.362 x 0.591	1.772	580
63 x 10	48	16	2.480 x 0.394	1.890	232
63 x 12	48	25	2.480 x 0.472	1.890	363
63 x 15	48	40	2.480 x 0.591	1.890	580
80 x 12	65	16	3.150 x 0.472	2.559	232
80 x 15	65	25	3.150 x 0.591	2.559	363
80 x 20	65	40	3.150 x 0.787	2.559	580
100 x 15	80	16	3.937 x 0.591	3.150	232
100 x 20	80	25	3.937 x 0.787	3.150	363
100 x 25	80	40	3.937 x 0.984	3.150	580
125 x 15	100	10	4.921 x 0.591	3.937	145
125 x 20	100	16	4.921 x 0.787	3.937	232
125 x 25	100	25	4.921 x 0.984	3.937	363
135 x 25	110	25	5.315 x 0.984	4.331	363
150 x 20	125	10	5.906 x 0.787	4.921	145
150 x 25	125	16	5.906 x 0.984	4.921	232
150 x 30	125	25	5.906 x 1.181	4.921	363
175 x 20	150	10	6.890 x 0.787	5.906	145
175 x 25	150	16	6.890 x 0.984	5.906	232
175 x 30	150	25	6.890 x 1.181	5.906	363
200 x 20	175	8	7.874 x 0.787	6.890	116
200 x 25	175	10	7.874 x 0.984	6.890	145
200 x 30	175	16	7.874 x 1.181	6.890	232
250 x 25	225	8	9.843 x 0.984	8.858	116
250 x 30	225	10	9.843 x 1.181	8.858	145
265 x 30	240	8	10.433 x 1.181	9.449	116

Bending strength	≥ 160 N/mm <sup>2</sup>	23,000 psi
Surface compressive stress	≥ 100–140 N/mm <sup>2</sup>	14,500–20,000 psi
Parallelism	≤ 0.20 mm	0.008 inches
Flatness <sup>1</sup>	Diameter:	up to 100 mm ≤ 0.05 above 100 to 150 mm ≤ 0.08 above 150 to 200 mm ≤ 0.12 above 200 mm ≤ 0.15
Thermal shock resistance	ΔT 230 °C	
Max. permissible temperature	300 °C	572 °F
Protected with mica	320 °C	608 °F

### Dimensional tolerances acc. to DIN 7080

#### Diameter

up to 150 mm	± 0.5 mm
150 to 200 mm	± 0.8 mm
above 200 mm	± 1.0 mm

#### Thickness

up to 20 mm	+ 0.50 mm /- 0.25 mm
above 20 mm	+ 0.80 mm /- 0.40 mm