

Lumistar Luminaire SLM-LED in high quality cast aluminium alloy version

Sizes: 65, 80, 100, 125

- **for use coupled with screwed sight glass fittings**

For the combination of sight and light port, suited to circular screwed sight glass fittings to DIN 11851 or similar

- **Application:**

For the internal illumination of bio-reactors, laboratory mixers, filters, as well as internals of pressure vessels, storage tanks, stirred vessels, pipelines and other normally enclosed systems in non explosion hazardous areas. Particularly suitable for pharmaceutical and food processing industries, e. g. breweries, dairies etc.

- **Protection:**

When correctly fitted, dust and water jet proof to IP 65 according to EN 60529/DIN VDE 0470 part 1

- **Operating conditions:**

Independent of internal vessel pressure/vacuum; max. permissible ambient temperature: 40°C

- **Electrical data:**

Operating voltage/power:

SLM 65-LED:

12-24 V DC – 2.5 W (the polarity must be observed, see table)

Colour temperature: 5000 K

Luminous flux: 215 lm

Beam angle: 18°

SLM 80-LED bis SLM 125-LED:

24 V AC/DC – 5.5 W

Colour temperature: 6500 K

Luminous flux: 585 lm

Beam angle: 18° or 25°

- **Transformers** or electronic power supplies 230 V/12V or 24 V can be supplied on request.

- **Built-in switch:** The Lumistar luminaires SLM-LED can be supplied with or without built-in push button switch

- **Mechanical installation:**

- Caution: Do not look into light – danger of impaired eyesight!
- Remove slotted cover nut from sight glass unit
- Pass cover nut over luminaire body
- Check that glass disc correctly seated in fitting
- Place cover nut with luminaire over weld nozzle and tighten nut

- **Caution:** Only after mechanical installation can electrical connection be made

- **Important note to installation:**

If luminaire SLM-LED is to be fitted to an existing screwed sight port, a matching slotted cover nut should be ordered with the luminaire or the existing cover nut modified to suit. Dimensions see table on the back.

CE

3755.668

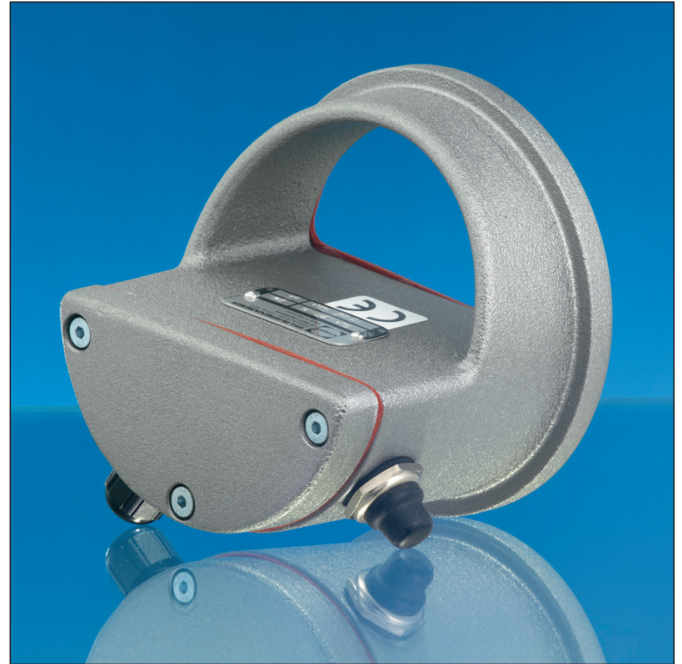

Lumistar luminaire SLM-LED

- **The polarity must be observed:**

12-24 V DC	24 V AC/DC
(+)	(~)
(-)	(~)
(⊥)	(⊥)

- **Electrical connection:**

- Select correct cable to suit operating conditions
- Cable diameter must suit cable entry gland (3.5-7 mm)
- Loosen lamp box cover screws and remove cover
- Pass cable through gland and wire to terminals
- Tighten gland
- Fit undamaged gasket to lid and tighten screws

• **Dimensions and electrical data for Lumistar luminaire SLM-LED:**

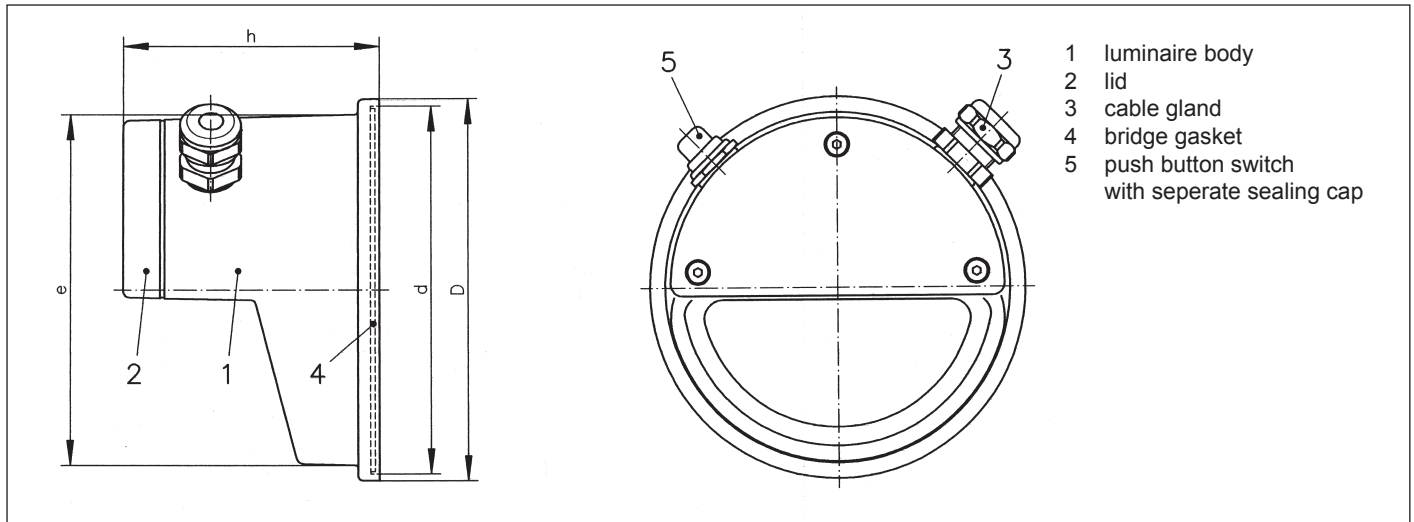

• **Parts construction and materials:**

- Luminaire of corrosion resistant die cast aluminium alloy, painted RAL 9007 (also available in stainless steel: Lumistar luminaire ME-LED)
- Suitable for use in food processing
- Luminaire lid (2) with resilient gasket screws onto luminaire body (1) (terminal box)

Size		1	2	3	4
Lumistar luminaire	Type	SLM-LED 65	SLM-LED 80	SLM-LED 100	SLM-LED 125
Compatible with screwed sight glass fittings to DIN 11851 or similar	DN	65	80	100	125
Voltage	V	12-24 V DC	24 V AC/DC	24 V AC/DC	24 V AC/DC
Wattage	W	2.5	5.5	5.5	5.5
Dimensions	D	90	102	123	151,5
	d	84	96	118,5	146,5
	e	78	92	113	136
	h	66	76	83	89
Slotted nut opening to DIN 11851		80	94	115	138
Weight approx.	kg	0.320	0.430	0.770	0.920
Part no. with push button		3544.601.00	3544.621.00	3544.641.00	3544.661.00
Part no. without push button		3544.602.00	3544.622.00	3544.642.00	3544.662.00

• **Combination:**

Lumistar luminaire SLM-LED 125 can be combined with Lumiglas sight glass wiper SW I

• **Ordering Information:**

e.g. Lumistar luminaire SLM-LED 80, 24 V AC/DC – 5.5 W, 18°, part no. 3544.621.00