

Sightglass Wiper with flexible drive type SW II BW

DATA SHEET 02.02

- for use with circular sightglass assemblies to DIN 28120 or similar -

Mounting:

By means of pressure tight glands through both base and cover flange of sightglass assembly; suitable for sightglass discs corresponding to DIN 7080 or DIN 8902.

Application:

For manually activated cleaning, when required, of inside face of glass in sight ports. Particularly suitable for pressure and vacuum, vessels requiring test certification both in **explosion hazardous** as well as non hazardous operating areas. The glass discs fitted into the assemblies correspond to DIN 7080 or DIN 8902 standards. Suitable for circular sightglass assemblies nominal size DN 100 to 200.

Operating conditions:

Vacuum tight; pressure tight to 16 bar.
Max. permissible temperature: 220° C (depending, however, on type of glass disc used).

Possible combinations:

Simultaneous fittings of Lumiglas luminaire, flame proof or standard design, is possible with the wiper SW II BW, as is the fitting of a spray device.

Certification/Testing:

Test certificates issued by the state material testing authority Nordrhein Westfalen, Dortmund, are available.

Assembly/materials alternatives

for the complete supply:

Wiper blade: PTFE or silicon rubber
All product contact parts are of stainless steel.
Mechanical drive internal seal: PTFE

- Item 1 ratchet drive lever mechanism
- 2 threaded gland bushes
- 3 guide tube for flexible drive shaft
- 4 wiper blade holder with wiper blade

Assembly and installation instructions:

The wiper is actuated by flexible shaft which engages at one end in the wiper blade holder and at the other in a lever operated ratchet drive mechanism which ensures drive shaft is always rotated in same direction.

A separate set of detailed installation instructions is included in the supply.

Should you order a complete sightglass assembly with the wiper type SW II, the additional machining of the base will be carried out by Papenmeier.



Sightglass Wiper type SW II BW mounted into sightglass fitting DIN 28120.

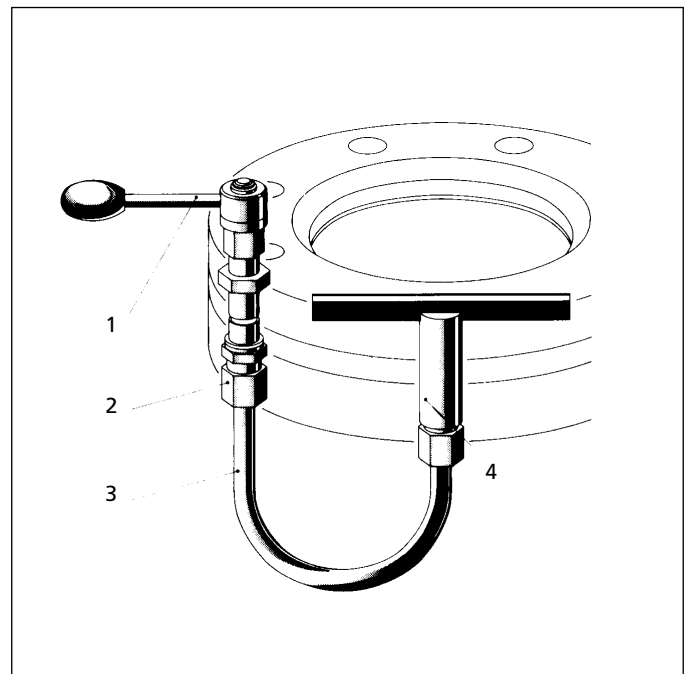

Sketch of assembly

Dimensions for Sightglass Wipers type SW II BW

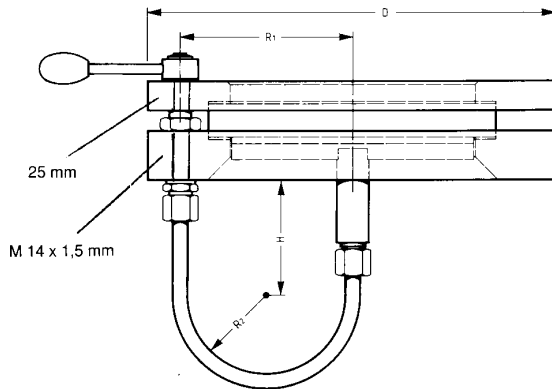

size		1	2	3	4
nominal bore assembly	DN	100	125	150	200
viewing diameter	d_1	125	150	175	225
wiper	D	220	250	285	340
	R 1	93	105	120	147.5
	R 2	41.5	47.5	55	68.7
	H	79.5	70	87.5	66
part no.		7223.034.00	7223.035.00	7223.036.00	7223.037.00

Spare parts

wiper blades	for size DN	wiper blade length (mm)	silicon part no.	PTFE part no.	
	1/100	122	9468.020.00	9468.031.00	
	2/125	148	9468.021.00	9468.032.00	
	3/150	174	9468.022.00	9468.033.00	
	4/200	222	9468.023.00	9468.034.00	
flexible drive	for sizes	part no.			
	1/100	9323.014.00			
	2/125	"			
	3/150	9323.016.00			
	4/200	"			

Ordering information:

E.g. LUMIGLAS Sightglass Wiper type SW II BW, size 3, wiper blade silicon rubber.

For ordering with complete sightport assembly please give the following additional information:

1. Sightglass assembly (DN/PN), materials.
2. Type and size of sightglass disc (borosilicate/sodalime).